



## Powerful Combination of ELAN DRC ICP-MS and seaFAST™ Sampling System Enables Calscience to Carry Out the High-Throughput Analysis of Seawater Samples for Trace Elements

The determination of trace elements in seawater presents unique challenges for ICP-MS that are rarely encountered with any other type of sample. The extremely high concentration of matrix components such as sodium, magnesium and chloride ions, create polyatomic spectral interferences, which make the determination of elements like As, Cr, V, Fe, Se, etc. extremely problematic. In addition, the routine aspiration of seawater (approximately 3% dissolved solids), even when diluted, will rapidly lead to salts

being deposited in and around the sampler and skimmer cone orifices as well as on the ion optics, leading to long-term signal stability problems. Even when sample dilutions of 10-20 fold are used to minimize these effects, the interface region will still need regular maintenance and cleaning to remove the salt buildup on the cones and lens system. Additionally, dilution is not a realistic option when ultratrace analyte levels are required. Over the years, alternative approaches such as matrix separation, analyte preconcentration, flow injection and reductive precipitation techniques have been tried with limited efficiency. However, none of these techniques could be considered truly routine because they were very labor intensive and also prone to contamination issues. As a result, they were acceptable for small numbers of samples, but could not be applied to high-throughput analysis.

## Calscience Environmental Laboratories

These limitations are well-recognized by the environmental analytical community, particularly by large contract labs such as Calscience Environmental Laboratories, Inc. that carry out high-throughput analysis. A PerkinElmer® ELAN® DRC™ ICP-MS user since 2003 and headquartered in Garden Grove, California (CA), Calscience is a full-service environmental testing company, offering analysis of groundwater, storm water, hazardous waste, marine sediments, seawater, and ambient air samples. One of their growth objectives is the testing of marine sediments, seawater, elutriates (supernatant from dredging simulation), and tissues in support of dredging operations at the major California port authorities including San Diego, Long Beach, Los Angeles, and those in the San Francisco Bay area. These types of samples from port and harbor marine environments can be especially challenging, not only because of the salt content, but also because they may contain petroleum hydrocarbons, pesticides, PCBs, and other semi-volatile compounds.

Calscience had tried most of the established analytical techniques for carrying out trace metal determinations on these kinds of marine samples, including a combination of the “dilute and shoot” method and the reductive/precipitation preconcentration technique. The preconcentration technique in particular was a long and involved process, which included a minimum of 15-hour reaction time to precipitate the trace analytes with a reducing chemical such as sodium borohydride from a large volume of seawater (typically 200 mL). The precipitated analytes are then typically dissolved in dilute acid and measured by ICP-MS. For a large suite of elements, the entire process generally takes a full 24 hours.

So in early 2009, Steve Lane, one of the founders of the company, realized that they needed to find a much faster way to analyze seawaters using U.S. EPA Method 1640<sup>1</sup> and invited several ICP-MS manufacturers to present their ideas. This is where PerkinElmer introduced Calscience to ESI and the seaFAST™ sample introduction accessory. One of the very first pieces of data they showed him was a poster presented at the 2009 Pittsburgh Conference in Chicago which showed that the seaFAST™ system coupled to an ELAN DRC ICP-MS could turnaround a sample for a suite of 10 elements in approximately 10 minutes.<sup>2</sup> As Steve put it:

*“I couldn’t believe what I was seeing. It would have taken us all day to determine that many elements in one of our marine samples. Here was a method that was automatically determining a suite of elements in neat, undiluted seawater in just over 10 minutes and at significantly lower detection limits than our reduction/precipitation method. It was very impressive.”*

After lengthy discussions with ESI and the local PerkinElmer sales and support specialists, Steve and the Calscience technical staff spent a couple of months evaluating the system and running samples. He was eventually convinced that it could work on his seawater and marine sediment samples and finally wrote up the justification to purchase a seaFAST™ sample introduction accessory soon after. When the instrument was delivered about a year ago, it was immediately hooked up to their second ELAN DRC ICP-MS that they purchased in 2006. The system was set up and running within a week in its basic configuration, and it took another couple of months for the hardware and software customization needed for the full capability desired by Calscience

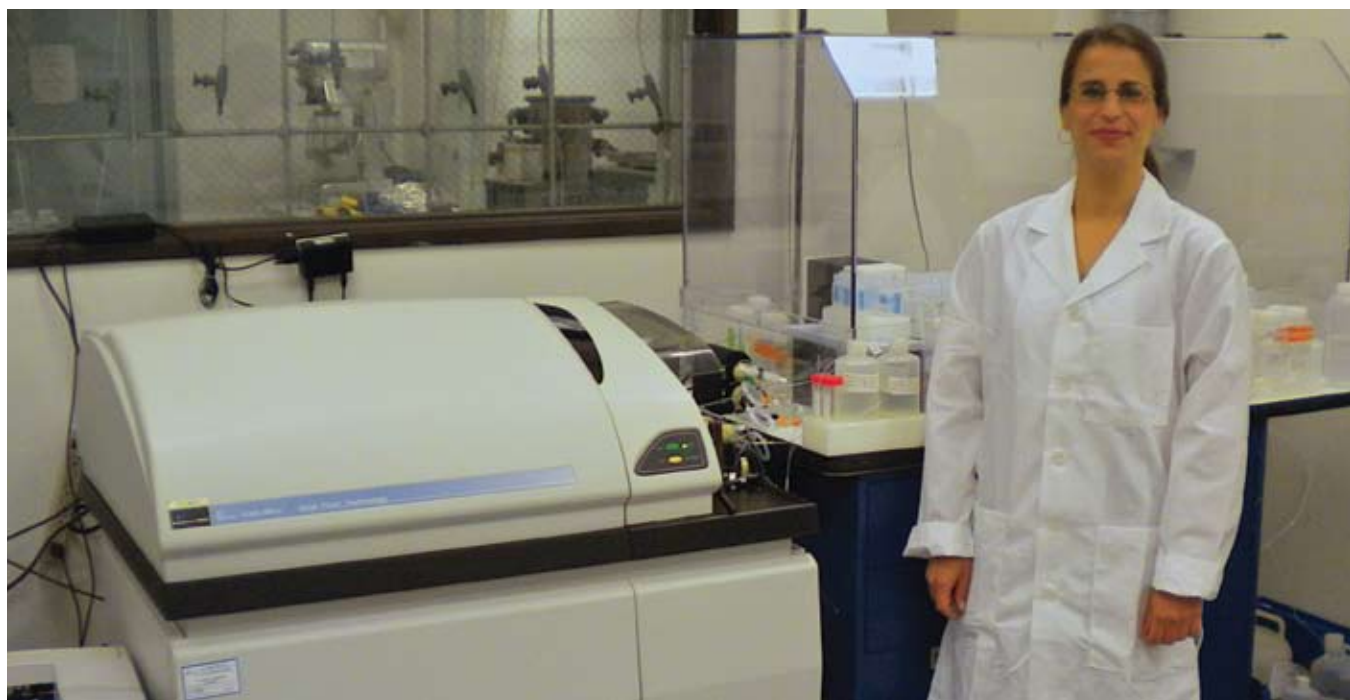

PerkinElmer ELAN DRC ICP-MS coupled with ESI seaFAST™ sample introduction accessory at Calscience Environmental Laboratories.

and to get the ICP-MS operators familiar with the analytical methodology. Since the additional capabilities were added, Calscience has been able to simultaneously determine 18 elements (at ppt-ppb levels) in their seawater samples using a combination of direct aspiration with dilution, matrix separation with preconcentration and hydride generation.

### How Does the System Work?

In its basic design, the seaFAST™ incorporates two high-purity injection valves. The system takes up an aliquot of the seawater sample in a loop on one inert high-purity injection valve and preconcentrates the elements of interest on a PFA chelation column, packed with a resin containing iminodiacetate acid (IDA), attached to a second valve. Under the optimum pH conditions, the column chemistry allows Na, Cl, Mg, and Ca matrix ions to pass through, while the concentrated analyte metals (typically transition elements and/or rare earth elements, if required) are then eluted into a nebulizer and detected using the ELAN DRC ICP-MS.<sup>3</sup> A schematic of this system, which is known as the seaFAST™ 1,

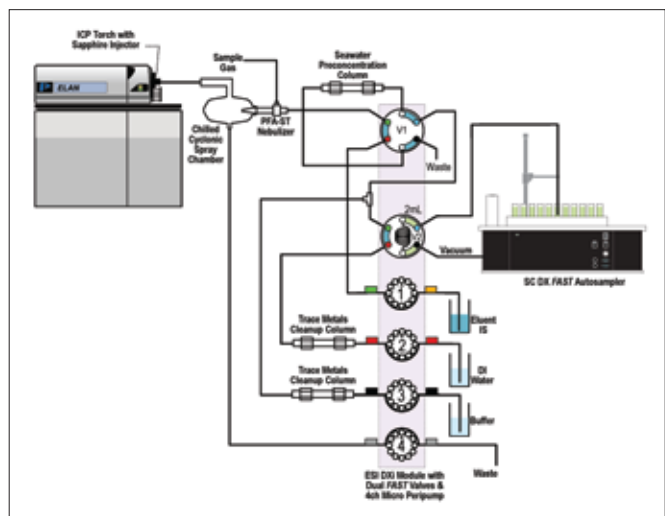

Figure 1. A schematic of the ELAN DRC ICP-MS and seaFAST™ 1.

is shown in Figure 1. Figure 2 shows the matrix separation/preconcentration process on the left (2A) and the resulting transient peak from 100 ppt of a group of analytes generated by the ELAN DRC ICP-MS on the right (2B).

However, the system used by Calscience has been refined even more. In addition to carrying out the matrix separation/analyte preconcentration step shown in Figure 2, it also utilizes two further steps described below to determine an even larger suite of elements:

- An auto dilution/addition step to directly aspirate the diluted seawater into the ICP-MS and automatically add an internal standard to determine elements that don't require a preconcentration step.
- A hydride generation mode, which includes a batch mixing chamber required to determine the hydride forming elements, such as As, Se and Sb.

This setup, known as the seaFAST™ 3, allows Calscience to automatically determine all the metals of interest in the seawater samples, using the 3 different steps/modes mentioned, in approximately 10 minutes.<sup>4</sup> A temporal breakdown of the separate automated sampling procedures is shown in Table 1.

**Table 1. Breakdown of the different sampling steps (and times) used to determine 15 elements in seawater using the 3 modes of the ESI seaFAST™ 3 coupled to the ELAN DRC ICP-MS.**

Automated Procedure	Time (min)
Load sample onto preconcentration column – measure direct mode	2
Wash column to remove matrix – measure hydride mode	3
Acid elute concentrated metals from column	2-3
Condition column prior to next sample	3
Total time per sample	10-11

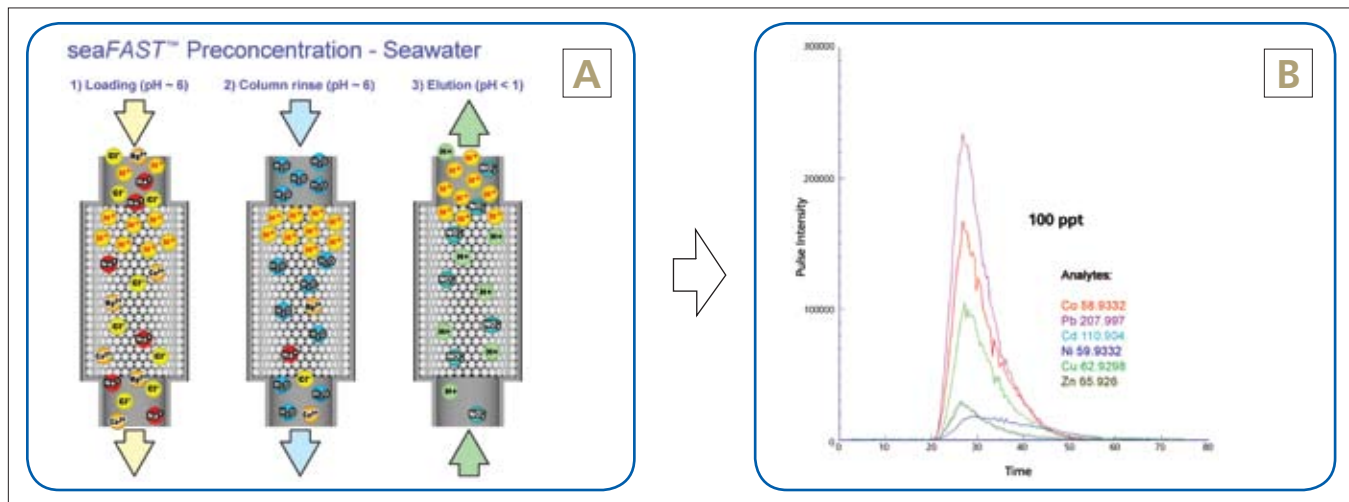

Figure 2. Matrix separation and analyte preconcentration of seawater using the seaFAST™ 1 (A) and the resulting transient peak from 100 ppt of a group of analytes generated by the ELAN DRC ICP-MS (B).

## Technical and Service Support

Steve Lane will be the first to admit that it was a concerted effort by both ESI and PerkinElmer to get this analytical method to work in a seamless manner. Not only did it require the on-line chemistries to be in sync with the sampling and measurement protocols, but it was further complicated by the fact that some of the elements like Fe, Cr, V and Cu required the use of ammonia as a DRC reaction gas to minimize the polyatomic spectral interferences generated by a combination of the matrix, the solvent and the argon gas ions.

However, with a complex system like this, the support is absolutely critical – from the application and technical support specialists who have to make sure the methodology is working correctly, to the service engineers who have to fix things when they go wrong or break down. It is well-accepted that the PerkinElmer support network is among the best in the industry. So it is very fortunate that in its collaboration with ESI, PerkinElmer has found a partner who is equally concerned about the well being of the customer. There is no doubt that this has contributed to the success of installation of the ELAN DRC ICP-MS and seaFAST™ 3 at Calscience. This was confirmed by Steve Lane when he remarked:

*"We have always found the technical and service support of PerkinElmer and its partners to be nothing less than extraordinary. Whether it is a new installation or preventative maintenance, their service engineers always conduct themselves in a very professional manner. If they encounter a particularly difficult problem and require additional parts, they usually arrive in a timely manner. We have also found their technical and application support people to be equally as impressive."*

There is no question that the ELAN DRC ICP-MS and ESI seaFAST™ 3 system at Calscience offer unique capabilities for the analysis of seawater samples that cannot be offered by any other company. The ability to determine 15 trace elements or more at the ppt level in approximately 10 minutes makes the high-throughput analysis of seawater samples a reality that could not have been envisioned a few years ago.

This kind of capability fits in with the vision of Calscience that prides itself on having all its cutting-edge instrumentation in a single location. Because of this, they are able to offer in-house analytical capabilities without the need to use

outside subcontractors, which in turn allows them to have more control over the quality and the cost of their services. Another key to Calscience's success is the technical expertise of their nearly 130 highly trained staff members, most of them with advanced degrees, who develop the methods and run the instruments.

We'll leave the final words to Steve Lane:

*"We are a very customer-focused organization. Through the quality of our service and the loyalty of our clients, Calscience has grown to become one of the largest environmental testing laboratories in California. By having analytical equipment of the highest quality like the ELAN DRC and seaFAST™ 3, combined with high-caliber scientists, we are continually pushing ourselves to be the market leaders in the very competitive world of environmental analysis."*

PerkinElmer and ESI are very pleased that Calscience has put their trust in this partnership to achieve their goals.

## Further Reading

1. EPA Method 1640 – Determination of trace elements in ambient waters by on-line chelation and preconcentration – EPA 821-R-95-033, April 1997: <http://www.epa.gov/waterscience/methods/method/files/1640.pdf>
2. Trace Metal Determination in Undiluted Seawater by ICP-MS by Matrix Removal and Preconcentration Using an Automated Dual Valve System, *PittCon 2009 Poster Presentation # 1930-17P*; Nathan J. Saetveit, Patrick A. Sullivan, Cory T. Gross, Daniel R. Wiederin – Elemental Scientific Inc., Omaha NE.
3. The Analysis of Undiluted Seawater by Preconcentration and Matrix Removal: *ESI Application Note*: [http://www.elementalscientific.com/PDF/Trace\\_Seawater\\_Analysis.pdf](http://www.elementalscientific.com/PDF/Trace_Seawater_Analysis.pdf)
4. Automated, Multimode ICP-MS Determination of Trace Elements in Undiluted Seawater: Simultaneous Preconcentration and Matrix Removal, Hydride Generation, and Online Dilution; *2010 PittCon Poster Presentation # 2030-5P*; Nathan Saetveit, Patrick Sullivan, Paul Watson, and Dan Wiederin – Elemental Scientific Inc., Omaha, NE and Steve Lane, Calscience Environmental Laboratories, Inc., Garden Grove, CA.

PerkinElmer, Inc.  
940 Winter Street  
Waltham, MA 02451 USA  
P: (800) 762-4000 or  
(+1) 203-925-4602  
[www.perkinelmer.com](http://www.perkinelmer.com)



For a complete listing of our global offices, visit [www.perkinelmer.com/ContactUs](http://www.perkinelmer.com/ContactUs)

Copyright © 2010, PerkinElmer, Inc. All rights reserved. PerkinElmer® is a registered trademark of PerkinElmer, Inc. All other trademarks are the property of their respective owners.

009363\_01